

**INSTRUCTIONS FOR INSTALLING YOUR WESLOCK PRODUCT**

**Leighton Dummy - Entry Handle**



**PARTS INCLUDED**

**Exterior Grip Assembly**

Exterior handle & thumb piece.



**Interior Lever/Knob Assembly Reversible**

Interior knob / lever, rosette & spindle

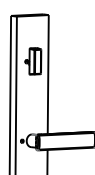

**Exterior Deadbolt Assembly**

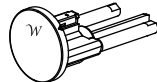

**Foot Screw Cap Assembly**



\* Only use one (1-2/5" OR 1-4/5") screw based on thickness of door.

**Assembly Screws (x8)**

Pre-installed on Exterior Grip Assembly for mounting interior knob / lever assembly. (1-2/5" OR 2")



For mounting interior deadbolt assembly. (1-2/5" OR 2")

**REQUIRED TOOLS**

**Measuring Tape**

Or other measuring tool

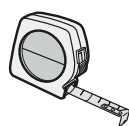

**Screwdriver**

Phillips and flat blade

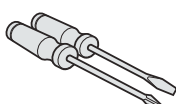

**Wood Chisel**

\*Only if prepping a new door

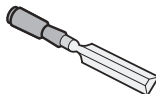

**Allen Wrench**

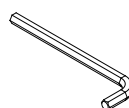

**Writing Utensil**

\*Only if prepping a new door

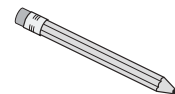

DOOR PREP INSTRUCTIONS 2 WESLOCK.COM

**INSTALLATION**

Deadbolt latch must be extended prior to installation.

**7A. Install Exterior Deadbolt and Grip Assemblies**

**A.** Insert deadbolt tailpiece into cam in deadbolt latch.

**B.** Align notches on grip housing with proper grooves (2-3/8" or 2-3/4") on latch. Slide on. At same time, align and insert foot screw through pre-drilled hole.

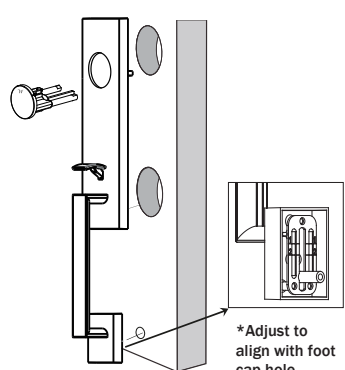

**7B. Install Interior Deadbolt and Knob/Lever Assemblies**

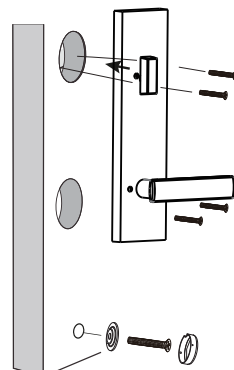

\*Adjust to align with foot cap hole

**THANKS FOR CHOOSING US. WE HOPE YOU ENJOY YOUR NEW WESLOCK DOOR HANDLE.**

**WESLOCK WARRANTY INFORMATION**

WESLOCK warrants to the purchaser that the products shall be free from defects in material workmanship for the LIFETIME of the product. Provided the product was purchased from an authorized WESLOCK dealer, Weslock's sole obligation under this warranty shall be to repair or replace product which WESLOCK determines to be defective. After such product is returned to WESLOCK by the purchaser with proof of purchase and with shipping charges prepaid, will this warranty be honored. Homeowner - if the product was installed as original equipment on a new home, you must provide the name of the builder, the date the home was built and your move-in date. If a mechanical defect has occurred, it is your right by this warranty to contact Customer Service in Tulsa, Oklahoma at (800) 575-2658 to arrange the return of the lock. This warranty DOES NOT cover products which malfunction due to improper installation or misuse. **Please register your product at Weslock.com.**

**WARRANTY TERMS**

**FINISH**

**MECHANICAL**

Transitonale Collection

Limited 5 year finish

Limited 25 year

**ADDITIONAL CUSTOMER RESOURCES**

**Online**

**WEBSITE**

For our full product catalog, and video instructions, go to;

🌐 [www.weslock.com](http://www.weslock.com)

**TWITTER**

To learn about promotions, and other news, follow us at;

🌐 [twitter.com/Weslock1](https://twitter.com/Weslock1)

**YOUTUBE**

Browse our video library, or leave us comments at;

🌐 [youtube.com/WeslockDoorHardware](https://youtube.com/WeslockDoorHardware)

**FACEBOOK**

See what we're up to, or ask us a question at;

🌐 [facebook.com/WeslockDoorHardware](https://facebook.com/WeslockDoorHardware)

**Direct**

**PHONE NUMBER**

1-800-575-2658  
B O L T

**FAX NUMBER**

1-918-294-3869

**EMAIL**

[customerservice@weslock.com](mailto:customerservice@weslock.com)  
or  
[warranty@weslock.com](mailto:warranty@weslock.com)

# TEMPLATE

